

(3) LIFT HOLES AT 120°

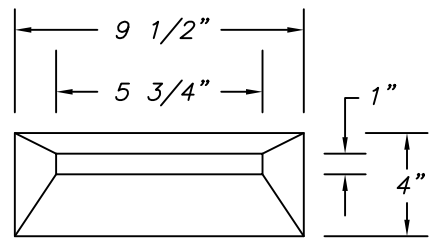

PLAN VIEW

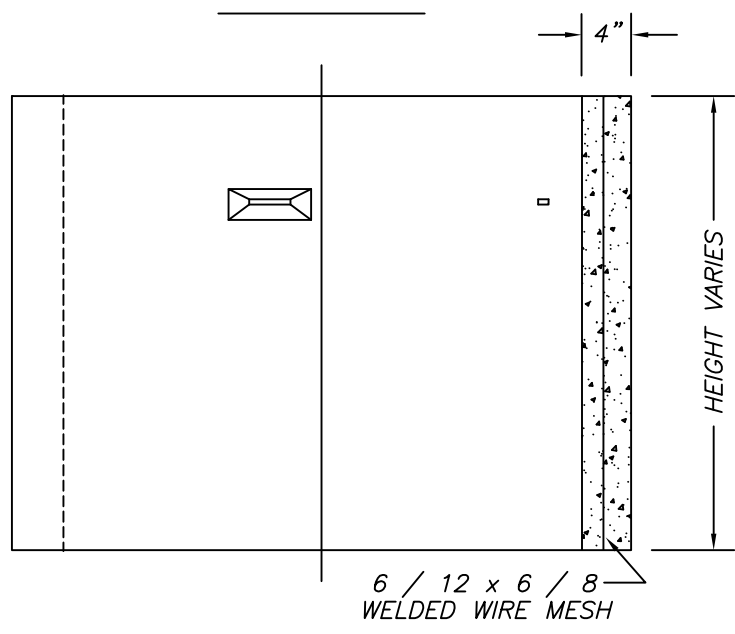

ELEVATION

SECTION

CONCRETE TO TEST 4000 PSI @ 28 DAYS
 WELDED WIRE MESH ASTM A-185

Precast Manufacturing Co. , LLC
 187 Strykers Road Phillipsburg , N.J. 08865
 Tel. (908) 454-2122 - Fax (908) 454-0512

SPECIFICATIONS			
RING HEIGHT	VOLUME C. F.	VOLUME GALLONS	APPROX. WEIGHT
3'-0"	205	1,536	4,600
4'-0"	274	2,048	6,100
5'-0"	342	2,559	7,600

CONT.		
JOB		
10'-0" DIA. SOLID RING		
DATE	DRAWN BY	DRAWING NO.
1 / 17	CLASSIC DESIGN	710-S