

PLAN VIEW

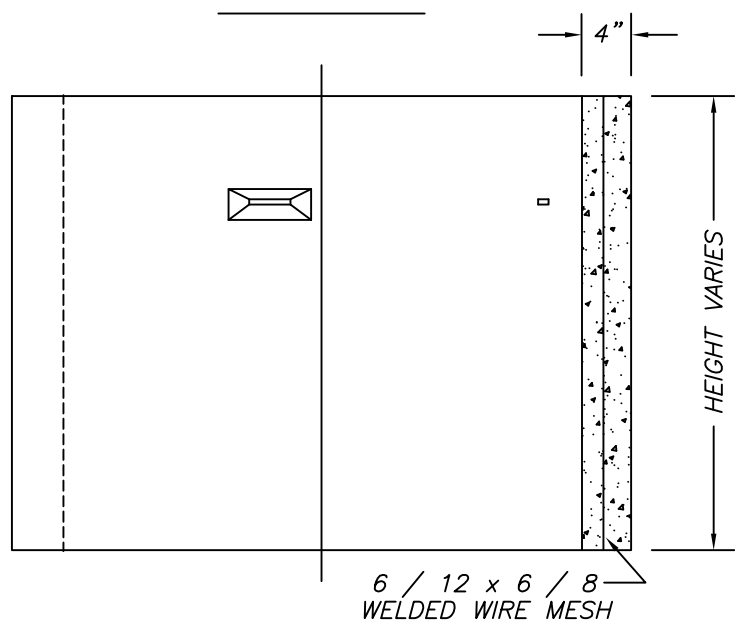
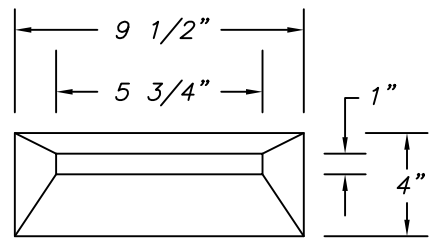

ELEVATION

SECTION

CONCRETE TO TEST 4000 PSI @ 28 DAYS
 WELDED WIRE MESH ASTM A-185

Precast Manufacturing Co. , LLC
 187 Strykers Road Phillipsburg , N.J. 08865
 Tel. (908) 454-2122 - Fax (908) 454-0512

SPECIFICATIONS			
RING HEIGHT	VOLUME C. F.	VOLUME GALLONS	APPROX. WEIGHT
3'-6"	148	1,106	4,300
4'-0"	169	1,264	4,900
4'-6"	190	1,422	5,500
5'-0"	211	1,580	6,100

CONT.		
JOB		
8'-0" DIA. SOLID RING		
DATE	DRAWN BY	DRAWING NO.
1 / 17	CLASSIC DESIGN	708-S