

**MANHOLE ASSEMBLY**

**APPROX. WEIGHTS:**

- BASE = 2800 LBS
- RISERS = 875 LBS/FT
- TOP SLAB = 1575 LBS
- 36" HIGH CONE = 2470 LBS

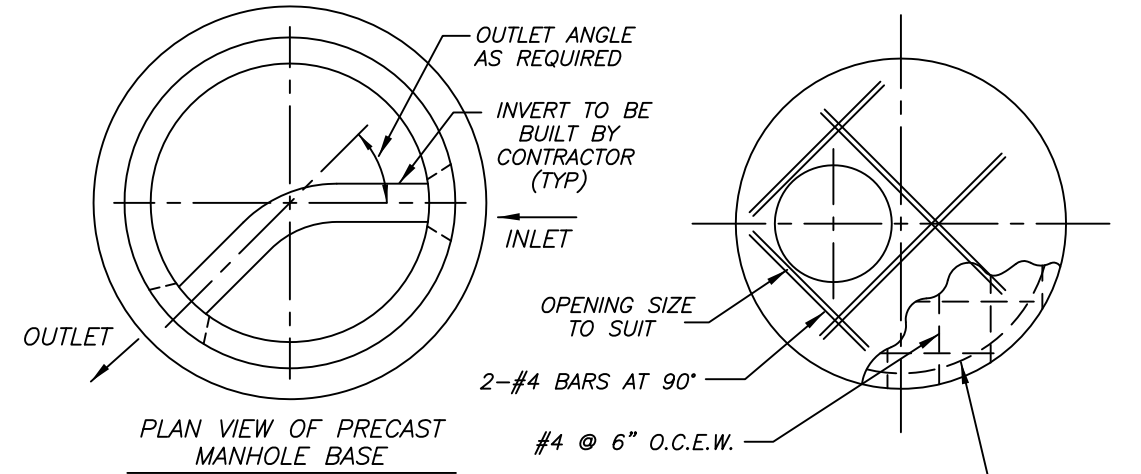

**PLAN VIEW OF PRECAST MANHOLE BASE**

**REINFORCEMENT LAYOUT FOR TOP SLAB**

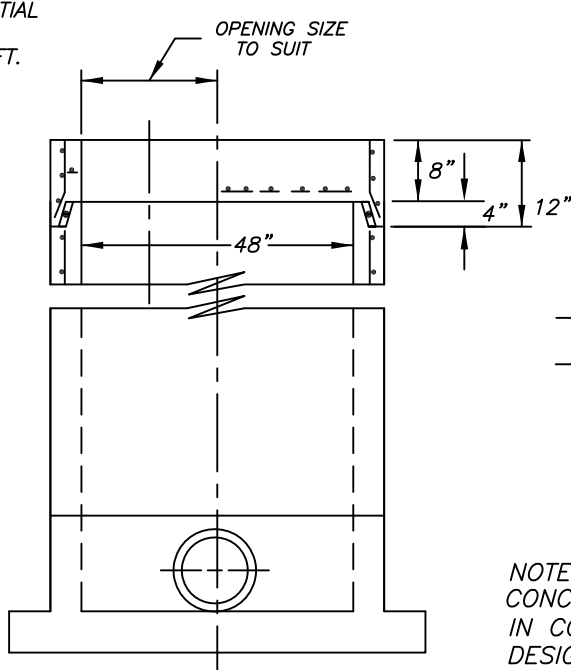

**TYPICAL 48" DIA MANHOLE WITH TOP SLAB**

NOTE:

CONE DIMENSIONS	
DIA OPENING	HEIGHT
24"	36"
30"	36"

NOTES:  
 CONCRETE TO TEST 4000 PSI @ 28 DAYS  
 IN CONFORMANCE WITH ASTM C-478  
 DESIGN FOR H2O LOADING

Precast Manufacturing Co. , LLC		
187 Strykers Road Phillipsburg , N.J. 08865		
Tel. (908) 454-2122 - Fax (908) 454-0512		
CONT.		
JOB		
4'-0" DIA. CONCRETE MANHOLE WITH SPREAD FOOTING - TYPICAL ASSEMBLY		
DATE	DRAWN BY	DRAWING NO.
1 / 17	CLASSIC DESIGN	3-4E